

Scan or click!

Order your free
sample pack:



Food & Beverage
sample pack

<http://surl.li/gkvlu>

HellermannTyton



Detectable Products for Food
and Beverage Processing



We brought the first detectable metal conte
Today we are leading the next generation of sol



nt tie onto the market.
utions

We understand the challenges you face

Contamination of food or beverages with foreign objects is a concern of all food processors. It can lead to costly production losses. But even graver, it can damage your reputation and brand and, worse still, threaten the lives of your customers.

Therefore it is even more important to have an experienced partner at your side who understands your safety, hygiene, quality assurance and verification needs when choosing a cable management solution for your production facilities.

HellermannTyton is the experienced partner at your side

We brought the first detectable metal content cable tie onto the market and today we are leading a new generation of proven metal content cable ties and other detectable cable management products. Our solutions are cost effective and go hand in hand with expert service support. This is good news for a highly automated, highly competitive food and beverage industry.

Innovative cable management solutions from HellermannTyton have been designed together with leading food processors to maximize quality assurance and verification using metal detectors, x-ray and visual means. Our solutions include new generation metal content ties, cable tie mounts, easy-to-clean conduits and fitting, corrosion resistant identification tags and other products and system solutions for your industry.

Each product has been manufactured from high-grade materials that comply with standards established by major regulatory bodies and are rigorously tested. Profit from our knowledge and experience, and from the high-quality of our detectable cable management solutions for food and beverage installations.

Your brand is your asset –
with HellermannTyton it is in good hands.



We understand the demands of the food a

Complying with regulatory standards

Complying with stringent regulatory standards:

We manufacture our products for food and beverage processing from high-grade materials. Most solutions are designed to conform to requirements of the US Food and Drug Administration (FDA), EC No. 1935/2004, as well as to various national standards. Our detectable metal content ties and other solutions are free of DEHP (Bis(2-ethyl(hexyl)phthalat), considered to be dangerous to health.



nd beverage industry.



Your partner with over 80 years’ experience in cable management solutions

From detectable cable ties and easy-to-clean PVDF heatshrink tubing, to corrosion-resistant identification tags, HellermannTyton provides innovative products and system solutions for the food and beverage industry. The extensive product portfolio reflects our long-standing industry expertise.

Wherever foreign objects might enter the food processing chain, it is crucial to use materials that are easily detectable in the production facility. We offer metal content products that are simple to detect, making an important contribution to quality management and helping you achieve compliance to HACCP.

Professional service: Our network of branch offices and distribution partners around the globe ensures a consistently high level of service, high flexibility and the fast response and delivery times you expect.

Solutions for your industry: Our metal content portfolio is ideal for applications in a wide variety of food and beverage sectors, including beverage production and filling, baking, meat processing as well as in dairy production.

Safety first. Quality first. HellermannTyton



Cable management solutions with a high level of Quality assurance and verification

Our contribution to your quality assurance

If a batch has been contaminated by a foreign object, quality has already been compromised. The high quality and reliability of our cable management solutions minimises the risk of contamination to consumers and proactively contributes to assuring the quality of your food and beverage operations.



el of detectability.

Metal content detectability – A unique level of verification

We know that accidents can happen. A cable tie may be accidentally cut or be damaged, allowing part or all of it to come in contact with food. Detection is crucial. Our metal content cable management solutions offer a high level of metal detectability. We offer a wide range of cable tie types with a metal detection range from a ferrous sphere setting of 1.0 mm up to 3.4 mm. In fact, our MCTS metal content cable tie sets a new benchmark for detectability of metal content ties in food and beverage installations.

Meeting the challenges of detectability

Food and beverage processors are conscious of the challenges faced in detecting contamination with foreign objects, especially plastic objects. Whether, and to what extent, a foreign object is detected depends on a constellation of factors such as material, the type of detector, equipment sensitivity, calibration, conveyance speed and the type of food being conveyed. It is important that metal in a plastic product is uniformly dispersed to allow detection of fragments. Depending on the application, a metal content tie might also need to be resistant to chemicals, high temperatures and to float in liquids.

Detectable solutions from HellermannTyton have been tested by METTLER TOLEDO UK and are developed specifically to meet these and other challenges.



Safe, sanitary and efficient food and beverage Unmatched cable management solutions



Stainless Steel Marker Plates

Non-corrosive M-BOSS stainless steel marker plates offer excellent resistance to inorganic acids, hydrochloric acid, and halogens. M-BOSS markers are ideal where high temperatures and / or chemical cleaning agents can have a damaging effect on identification in food production facilities.



ge processing.

Metal Content Ties and Mounts

Metal content products from HellermannTyton are detectable through metal pigments. We offer you a wide range of cable tie types such as MCT and MCTS with a metal detection range from a ferrous sphere setting of 1.0 mm up to 3.4 mm. Furthermore, MCTS ties are highly resistant to corrosion, making these particularly suitable for applications in salty environments or cleanrooms. A uniform dispersion of metal content in all cable ties and mounts makes fragments easily detectable. Metal content mounts are ideal for extra strength in holding MCT series cable ties in position. All metal content cable ties from HellermannTyton for the food and beverage industry are available in blue for high visual detectability. Cable ties can also be ordered in green, russet, mustard, yellow, red and orange.

Metal-Content Spiral Binding, Cable Covering and Fittings

SBPEMC spiral binding and the Helawrap HWPPMC cable covers are ideal for bundling and protecting cables and hoses, including retro-fitting. Both are highly flexible, corrosion resistant, and have a high metal content for reliable detection.

Stainless Steel Cable Ties and P-Mounts

Corrosion-resistant MBT cable ties and P-Mounts made of stainless steel are suitable for the high temperatures and substantial mechanical loads often found in food production processes.

Application Processing Tools

Designed for maximum ergonomics and performance, application processing tools from HellermannTyton combine reduced hand effort and durable components to ensure efficient assembly and longer life cycle.

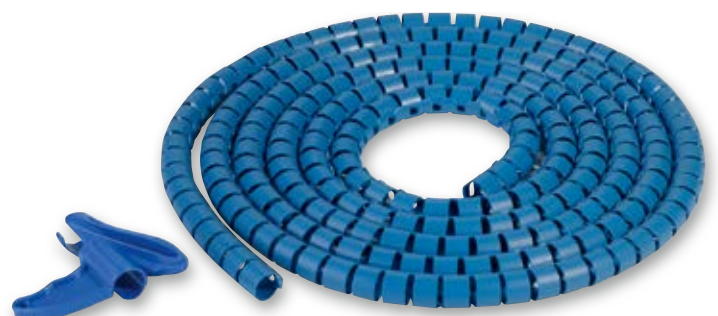

The ideal components for your application

Overview of products by feature

Requirements for quality food production processes are high. All solutions presented here conform to **REACH Directive (EC) no. 1907/2006** and are **DEHP-free (Bis(2 ethyl(hexyl) phtalat)**, a plasticizer deemed to be toxic for reproduction. All of our products contain special features tailored to food and beverage processing.



Detection

- Conforms to the HACCP approach
- Even fragments are detectable
- Contamination from plastic cut-offs is virtually impossible
- The MCTS variant is particularly suitable for use in saline environments with high humidity

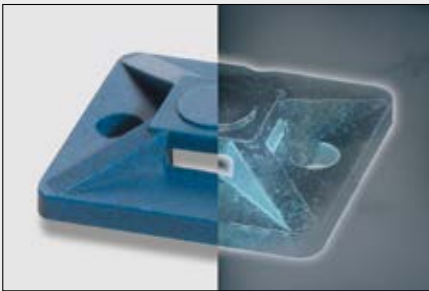

X-Ray Detection



Magnetic Detection



Visual Detection



Floating

- Products manufactured from PP and PE will float to the surface of liquids so the products can easily be seen and removed



Stainless Steel

- High temperature resistance
- Corrosion resistant & weather resistant



Easy-to-clean

- Flexible conduits which are easy to clean to protect cables against mechanical influences



Chemical resistance

- Marker plates are designed for use with stainless steel cable ties in harsh environments



requirements.

	Detection X-Ray	Detection Magnetic	Detection Visual	Floating	Stainless Steel	Easy-to-clean	Chemical resistance	Page
Cable Ties and Fixings								
Metal Content Ties and Mounts								
MCT-Series	•	•	•					14
MCT-Series releasable	•	•	•					14
MCTS-Series	•	•	•					15
MCT-Series / MCTS-Series PPMP	•	•	•	•			•	16
MCMB Series	•	•	•					17
MCCTAM	•	•	•					18
MCKR-Series with curved design	•	•	•					19
Stainless Steel Cable Ties and Mounts								
MBT SS304	•	•			•	•	•	20
MST SS304	•	•			•	•	•	23
SSPC	•	•			•		•	24
E/TFE Cable Ties and Mounts								
T-Series in E/TFE (Tefzel®) blue			•				•	25
KR-Mounts			•				•	26
Polypropylene Cable Ties								
T-Series in PP natural and black				•			•	27
Insulation								
TK20			•			•	•	28
TK29			•			•	•	29
TFE2			•			•	•	30
TFE4			•			•	•	31
Cable Protection Systems								
Helawrap HWPPMC	•	•	•	•			•	32
SBPEMC	•	•	•	•			•	33
PSRSC Smooth Bore/Cover PVC Spiral Reinforced Conduit						•	•	34
PSRSC-FMCFSS Fixed Comp. SS Food Fitting, Ext. Thread	•	•			•	•	•	35
Identification Systems								
Hellermark SSC					•	•	•	36
Hellermark - Carriers SSC					•	•	•	36
Hellermark - Carriers SSCPP						•		36
M-BOSS Compact	•	•			•	•	•	37
M-BOSS Compact Organiser	•	•			•	•	•	37
M-BOSS Compact & Lite Marker	•	•			•	•	•	38
M-BOSS Print Service	•	•			•	•	•	39
Laser Beam Marked Metal Plates and Ties	•	•			•	•	•	39

Detectable products for food and beverage

Innovative cable management solutions tailored

Your advantages at a glance

- Extreme temperature and chemical resistance
- Conform to the HACCP approach
- Fragments also detectable
- Meet material standards laid down by major regulatory bodies such as FDA
- Quality and verification based on development expertise and rigorous testing
- Best-fit solutions: HellermannTyton Products offer you an ideal combination of quality, cost effectiveness and service from one dependable source



processing.
to your needs



Cable Ties and Fixings
Page 14



Insulation
Page 26



Cable Protection Systems
Page 30



Identification Systems
Page 34



Application Tooling
Page 37



Cable Ties and Fixings

Cable Ties Inside Serrated

Cable Ties for food industry, detectable

• MCT-Series

The Metal Content Tie is a cable tie specifically designed for use in the food and pharmaceutical processing industries. A unique manufacturing process, involving the inclusion of a metallic pigment, enables even small 'cut-off' sections of the tie to be detected by standard metal-detecting equipment. Ideally suited for the installation of cabling in and around the manufacturing process.

Features and Benefits

- Total metal dispersion throughout the tie available in a wide range of sizes
- Usable as part of HACCP process*
- Blue colour for easy visual detection
- Greatly reduces risk of contamination
- Magnetic and X-Ray detectable (detection level depending on specific application)



One Step to the Web!

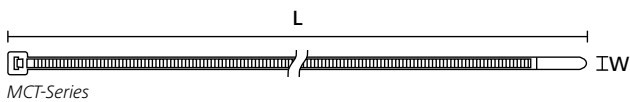

The MCT with metal content.

MATERIAL	Polyamide 6.6 with metal particles (PA66MP)
Operating Temperature	-40 °C to +85 °C, (+105 °C, 500 h)
Flammability	UL94 HB
Specifications	FDA, HACCP



TYPE	Width (W)	Length (L)	Bundle Ø max.	N	Material	Colour	Pack Cont.	Application Tool No.	Article-No.
MCT18R	2.5	100.0	22.0	80	PA66MP	Blue (BU)	100 pcs.	2-11	111-01225
MCT30R	3.5	150.0	35.0	135	PA66MP	Blue (BU)	100 pcs.	2-11	111-00829
MCT50R	4.6	202.0	50.0	225	PA66MP	Blue (BU)	100 pcs.	2-11	111-00830
MCT50L	4.7	380.0	110.0	225	PA66MP	Blue (BU)	100 pcs.	2-11	111-00831
	4.7	380.0	110.0	225	PA66MP	Green (GN)	100 pcs.	2-11	111-01169
	4.7	380.0	110.0	225	PA66MP	Orange (OG)	100 pcs.	2-11	111-01171
	4.7	380.0	110.0	225	PA66MP	Red (RD)	100 pcs.	2-11	111-01167
	4.7	380.0	110.0	225	PA66MP	Yellow (YE)	100 pcs.	2-11	111-01168
MCT120R	7.6	387.0	100.0	535	PA66MP	Blue (BU)	100 pcs.	3;9-12	111-01136

All dimensions in mm. Subject to technical changes.
Minimum Order Quantity (MOQ) may differ from package content. Other packaging options may also be available.

• MCT-Series releasable

TYPE	Width (W)	Length (L)	Bundle Ø max.	N	Material	Colour	Pack Cont.	Article-No.
MCTRELK2M	4.6	250.0	65.0	225	PA66MP	Blue (BU)	100 pcs.	111-00937

All dimensions in mm. Subject to technical changes.
Minimum Order Quantity (MOQ) may differ from package content. Other packaging options may also be available.

Application Tool No.										
2	3	4	5	6	7	8	9	10	11	12
MK20	MK21	MK3SP	MK3PNSP2	EVO7	MK7HT	MK7P	MK6	MK9	MK9HT	MK9P

For detailed information on Application Tooling please refer to our Main Catalogue or the Internet.

*HACCP stands for Hazard Analysis Critical Control Points. It is a method of identifying and eliminating potential hazards in food production. Those hazards that cannot be eliminated are controlled in such a way that the consumer is protected. These controls are known as Critical Control Points (CCPs). They are CRITICAL because if they fail or are not carried out, the risk of the product harming the customer, increases.



Cable Ties for food industry, detectable

• MCTS-Series

The Metal Content Tie is a cable tie specifically designed for use in the food and pharmaceutical processing industries. A unique manufacturing process, involving the inclusion of a metallic pigment, enables even small 'cut-off' sections of the tie to be detected by standard metal-detecting equipment. Ideally suited for the installation of cabling in and around the manufacturing process.

Features and Benefits

- Total metal dispersion throughout the tie available in a wide range of sizes
- Usable as part of HACCP process*
- Blue colour for easy visual detection
- Greatly reduces risk of contamination
- Magnetic and X-Ray detectable (detection level depending on specific application)
- MCTS ties have very good corrosion resistance



MCTS ties are highly resistant to corrosion.

MATERIAL	Polyamide 6.6 with metal particles (PA66MP+)
Operating Temperature	-40 °C to +85 °C
Flammability	UL94 HB
Specifications	HACCP

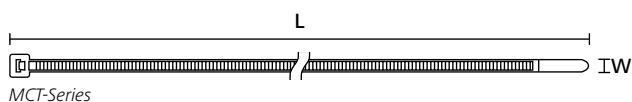

TYPE	Width (W)	Length (L)	Bundle Ø max.	N	Material	Colour	Pack Cont.	Application Tool No.	Article-No.
MCTS100	2.5	100.0	22.0	60	PA66MP+	Blue (BU)	100 pcs.	2-11	111-01341
	2.5	100.0	22.0	60	PA66MP+	Mint Green (MGN)	100 pcs.	2-11	111-01377
	2.5	100.0	22.0	60	PA66MP+	Mustard (MST)	100 pcs.	2-11	111-01380
	2.5	100.0	22.0	60	PA66MP+	Russet (RUS)	100 pcs.	2-11	111-01383
MCTS150	3.5	153.0	36.0	110	PA66MP+	Blue (BU)	100 pcs.	2-11	111-01342
	3.5	153.0	36.0	110	PA66MP+	Mint Green (MGN)	100 pcs.	2-11	111-01378
	3.5	153.0	36.0	110	PA66MP+	Mustard (MST)	100 pcs.	2-11	111-01381
	3.5	153.0	36.0	110	PA66MP+	Russet (RUS)	100 pcs.	2-11	111-01384
MCTS200	4.7	203.0	50.0	150	PA66MP+	Blue (BU)	100 pcs.	2-11	111-01343
	4.7	203.0	50.0	150	PA66MP+	Mint Green (MGN)	100 pcs.	2-11	111-01379
	4.7	203.0	50.0	150	PA66MP+	Mustard (MST)	100 pcs.	2-11	111-01382
	4.7	203.0	50.0	150	PA66MP+	Russet (RUS)	100 pcs.	2-11	111-01385
MCTS300	4.8	301.0	80.0	150	PA66MP+	Blue (BU)	100 pcs.	2-11	111-01399
	4.8	301.0	80.0	150	PA66MP+	Mint Green (MGN)	100 pcs.	2-11	111-01400
	4.8	301.0	80.0	150	PA66MP+	Mustard (MST)	100 pcs.	2-11	111-01401
	4.8	301.0	80.0	150	PA66MP+	Russet (RUS)	100 pcs.	2-11	111-01402

All dimensions in mm. Subject to technical changes.

Minimum Order Quantity (MOQ) may differ from package content. Other packaging options may also be available.

Application Tool No.									
2	3	4	5	6	7	8	9	10	11
MK20	MK21	MK3SP	MK3PNSP2	EVO7	MK7HT	MK7P	MK6	MK9	MK9HT

For detailed information on Application Tooling please refer to our Main Catalogue or the Internet.

*HACCP stands for Hazard Analysis Critical Control Points. It is a method of identifying and eliminating potential hazards in food production. Those hazards that cannot be eliminated are controlled in such a way that the consumer is protected. These controls are known as Critical Control Points (CCPs). They are CRITICAL because if they fail or are not carried out, the risk of the product harming the customer, increases.

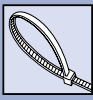

Cable Ties and Fixings

Cable Ties Inside Serrated

Cable Ties for food industry, detectable

- **MCT-Series / MCTS-Series PPMP**

The Metal Content Tie is a cable tie specifically designed for use in the food and pharmaceutical processing industries. A unique manufacturing process, involving the inclusion of a metallic pigment, enables even small 'cut-off' sections of the tie to be detected by standard metal-detecting equipment. Ideally suited for the installation of cabling in and around the manufacturing process.

Features and Benefits

- High chemical and temperature resistance
- Blue color for easy visual detection
- Greatly reduces risk of contamination
- Magnetic and X-Ray detectable
(detection level depending on specific application)
- MCTS ties have very good corrosion resistance
- Usable as part of HACCP process
- PP cable ties tend to float in various liquids



MCTPP ties will float to the surface of liquids so they can easily be seen and removed.

MATERIAL	Polypropylene with metal particles (PPMP+)	Polypropylene with metal particles (PPMP)
Operating Temperature	-40 °C to +85 °C	-40 °C to +115 °C
Flammability	not flame retarded	UL94 HB
Specifications	HACCP	FDA, HACCP

HF ✓

RoHS ✓

RoHS ✓

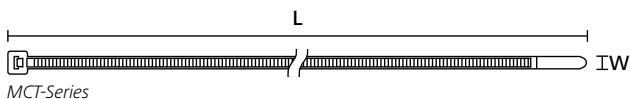

TYPE	Width (W)	Length (L)	Bundle Ø max.		Material	Colour	Pack Cont.	Application Tool No.	Article-No.
MCTPP18R	2.5	100.0	22.0	85	PPMP	Blue (BU)	100 pcs.	2-11	111-01664
MCTPP30R	3.5	150.0	35.0	130	PPMP	Blue (BU)	100 pcs.	2-11	111-01665
MCTPP50R	4.6	200.0	50.0	150	PPMP	Blue (BU)	100 pcs.	2-11	111-01666
MCTPP50L	4.6	390.0	110.0	150	PPMP	Blue (BU)	100 pcs.	2-11	111-01667
MCTS200	4.7	202.0	50.0	140	PPMP+	Blue Grey (BUGY)	100 pcs.	2-11	111-01386
MCTPP120R	7.6	387.0	100.0	380	PPMP	Blue (BU)	100 pcs.	2-11	111-01668

All dimensions in mm. Subject to technical changes.

Minimum Order Quantity (MOQ) may differ from package content. Other packaging options may also be available.

Application Tool No.									
2	3	4	5	6	7	8	9	10	11
MK20	MK21	MK3SP	MK3PNSP2	EVO7	MK7HT	MK7P	MK6	MK9	MK9HT

For detailed information on Application Tooling please refer to our Main Catalogue or the Internet.

*HACCP stands for Hazard Analysis Critical Control Points. It is a method of identifying and eliminating potential hazards in food production. Those hazards that cannot be eliminated are controlled in such a way that the consumer is protected. These controls are known as Critical Control Points (CCPs). They are CRITICAL because if they fail or are not carried out, the risk of the product harming the customer, increases.



Cable Tie Mounts for food industry, detectable

- **MCMB-Series**

MCMB mounts are ideally suited for holding MCT-Series cable ties in position, even in areas of high vibration such as food manufacturing equipment and automated packaging machines.

Features and Benefits

- Distinctive blue colour for easy visual detection
- Simple to install with a screw or bolt
- Provides a secure fixing solution for routing cables, tubes and hoses
- 4-way entry of the cable tie for a quicker and more flexible installation
- Magnetic and X-Ray detectable – perfect for use with food and pharmaceutical grade detection equipment
- Total metal dispersion provides consistent detectability, even for small 'cut-off' pieces
- Greatly reduced risk of contamination within food products
- Usable as part of HACCP process*



Detectable fixing solution containing of MCMB Mount and MCT cable tie.

MATERIAL	Polyamide 6.6 with metal particles (PA66MP)
Operating Temperature	-40 °C to +85 °C, (+105 °C, 500 h)
Flammability	UL94 HB
Specifications	FDA, HACCP

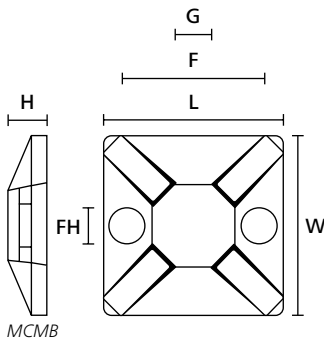

TYPE	Width (W)	Length (L)	Height (H)	Hole Ø (FH)	Strap Width max. (G)	Material	Colour	Pack Cont.	Article-No.
MCMB3	19.0	19.0	3.8	3,1	3.5	PA66MP	Blue (BU)	100 pcs.	151-01169
MCMB4	28.0	28.0	4.7	4,0	4.7	PA66MP	Blue (BU)	100 pcs.	151-01170

All dimensions in mm. Subject to technical changes.

Minimum Order Quantity (MOQ) may differ from package content. Other packaging options may also be available.

*HACCP stands for Hazard Analysis Critical Control Points. It is a method of identifying and eliminating potential hazards in food production. Those hazards that cannot be eliminated are controlled in such a way that the consumer is protected. These controls are known as Critical Control Points (CCPs). They are CRITICAL because if they fail or are not carried out, the risk of the product harming the customer, increases.

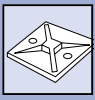

Cable Ties and Fixings

Cable Tie Mounts

Cable Tie Mounts for food industry, detectable

- **MCCTAM-Series, for applications where space is limited**

MCCTAM mounts are ideally suited for holding MCT-Series cable ties in position, even in areas of high vibration such as food manufacturing equipment and automated packaging machines.

Features and Benefits

- Distinctive blue colour for easy visual detection
- Suitable for applications with minimal space
- Mounted before cable installation and in line with cable
- CTAM has 4-way entry design for use in line or at 90° angle to cable run
- Magnetic and X-Ray detectable – perfect for use with food and pharmaceutical grade detection equipment
- Total metal dispersion provides consistent detectability, even for small 'cut-off' pieces
- Greatly reduced risk of contamination within food products
- Usable as part of HACCP process*



Detectable fixing solution containing of MCCTAM1 Mount and MCTS cable tie.



MCCTAM mounts, detectable, for applications with limited space.

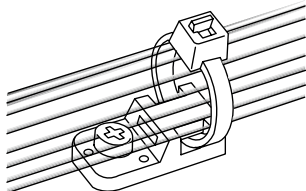

Cable Tie Mounts CTAM1/CTAM2

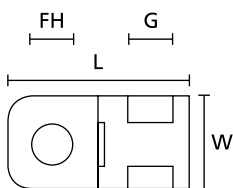

CTAM Series

MATERIAL	Polyamide 6.6 with metal particles (PA66MP+)
Operating Temperature	-40 °C to +85 °C
Specifications	HACCP



TYPE	Width (W)	Length (L)	Hole Ø (FH)	Strap Width max. (G)	Material	Colour	Pack Cont.	Article-No.
MCCTAM1	10.3	20.7	4,3	5.0	PA66MP+	Blue (BU)	100 pcs.	151-00997

All dimensions in mm. Subject to technical changes.
Minimum Order Quantity (MOQ) may differ from package content. Other packaging options may also be available.

*HACCP stands for Hazard Analysis Critical Control Points. It is a method of identifying and eliminating potential hazards in food production. Those hazards that cannot be eliminated are controlled in such a way that the consumer is protected. These controls are known as Critical Control Points (CCPs). They are CRITICAL because if they fail or are not carried out, the risk of the product harming the customer, increases.

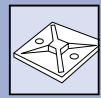

Cable Tie Mounts for food industry, detectable

- **MCKR-Series with curved design**

MCKR mounts with curved design are ideally suited for holding MCT-Series cable ties in position, even in areas of high vibration such as food manufacturing equipment and automated packaging machines.

Features and Benefits

- Distinctive blue colour for easy visual detection
- Curved design for additional cable support
- Simple to install with a screw or bolt
- Excellent security, particularly in areas of high vibration
- Magnetic and X-Ray detectable – perfect for use with food and pharmaceutical grade detection equipment
- Total metal dispersion provides consistent detectability, even for small 'cut-off' pieces
- Greatly reduced risk of contamination within food products
- Usable as part of HACCP process*



Detectable fixing solution containing of MCKR Mount and MCTS cable tie.



MCKR Mount, screwable, detectable.

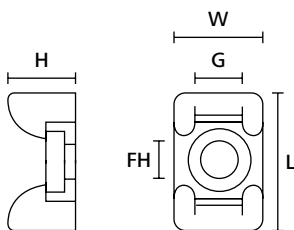

Cable Tie Mounts KR6G5, KR8G5 and CTM

MATERIAL	Polyamide 6.6 with metal particles (PA66MP+)
Operating Temperature	-40 °C to +85 °C
Specifications	HACCP



TYPE	Width (W)	Length (L)	Height (H)	Hole Ø (FH)	Strap Width max. (G)	Material	Colour	Pack Cont.	Article-No.
MCKR6G5	11.8	17.8	8.8	4,5	6.4	PA66MP+	Blue (BU)	100 pcs.	151-00950
MCKR8G5-5	14.3	24.8	12.0	5,2	8.3	PA66MP+	Blue (BU)	100 pcs.	151-01020

All dimensions in mm. Subject to technical changes.
Minimum Order Quantity (MOQ) may differ from package content. Other packaging options may also be available.

*HACCP stands for Hazard Analysis Critical Control Points. It is a method of identifying and eliminating potential hazards in food production. Those hazards that cannot be eliminated are controlled in such a way that the consumer is protected. These controls are known as Critical Control Points (CCPs). They are CRITICAL because if they fail or are not carried out, the risk of the product harming the customer, increases.



Stainless Steel Cable Ties with Ball-lock

MBT-Series, SS316

- Non-releasable locking feature
- Operating temperature -80°C to +538°C
- Corrosion and weather resistant
- Outstanding chemical resistance
- Anti-magnetic
- Non-burning

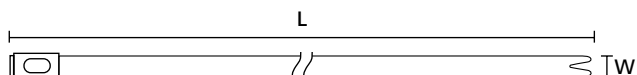

MBT-Series cable ties can be used in solar farms

HF ✓ RoHS ✓ LFH ✓

Type	Width (W)	Length (L)	Bundle Ø max	N	Material (p4)	Article-No.
MBT5S	4.6	127	25	670	SS316	911-01947
MBT8S	4.6	201	50	670	SS316	911-01948
MBT14S	4.6	362	102	670	SS316	911-01950
MBT20S	4.6	521	152	670	SS316	911-01952
MBT8H	7.9	201	50.8	1115	SS316	911-01949
MBT14H	7.9	362	102	1115	SS316	911-01951
MBT20H	7.9	521	152	1115	SS316	911-01953
MBT27H	7.9	681	203	1115	SS316	911-01954

All dimensions in mm. Subject to technical changes.

Recommended Tools

Type		
	HT338	MK9SST

Suitable for the following industries:



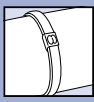

Cable Ties and Fixings

Cable Ties, Stainless Steel

Double Wrap Cable Ties with Ball-Lock

- MBTXHD- / MBTUHD-Series, Stainless Steel 316

The double wrap ties of the MBT-series are used in applications where a fixing requires an extraordinary high tensile strength.

Features and Benefits

- Stainless steel MBT ties with double wrap operation
- Wraps around the bundle and passes through the head twice
- Very high tensile strength to carry enormous applied loads
- Head with two locking balls
- Resistant to arduous conditions and environments



Double-Wrap Stainless Steel Cable Ties, uncoated, MBT_UHD.

MATERIAL	Stainless Steel (SS316)
Operating Temperature	-80 °C to +538 °C
Flammability	Non burning

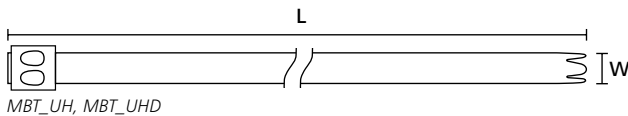
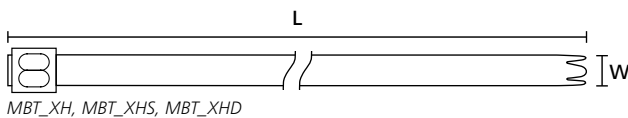

TYPE	Width (W)	Length (L)	Bundle Ø max.		Material	Pack Cont.	Application Tool No.	Article-No.
MBT27XHD	12.3	681.0	100.0	5,000	SS316	50 pcs.	15-16;18	111-01307
MBT33XHD	12.3	838.0	120.0	5,000	SS316	50 pcs.	15-16;18	111-01308
MBT43XHD	12.3	1,092.0	160.0	5,000	SS316	25 pcs.	15-16;18	111-01309
MBT49XHD	12.3	1,245.0	180.0	5,000	SS316	25 pcs.	15-16;18	111-01310
MBT60XHD	12.3	1,524.0	230.0	5,000	SS316	25 pcs.	15-16;18	111-01311
MBT27UHD	16.0	681.0	100.0	7,000	SS316	50 pcs.	17	111-01312
MBT33UHD	16.0	838.0	120.0	7,000	SS316	50 pcs.	17	111-01313
MBT43UHD	16.0	1,092.0	160.0	7,000	SS316	25 pcs.	17	111-01314
MBT49UHD	16.0	1,245.0	180.0	7,000	SS316	25 pcs.	17	111-01315
MBT60UHD	16.0	1,524.0	230.0	7,000	SS316	25 pcs.	17	111-01316

All dimensions in mm. Subject to technical changes.

Minimum Order Quantity (MOQ) may differ from package content. Other packaging options may also be available.

Application Tool No.			
15	16	17	18
MK9SST	MK9PSST	HDT16	KST-STG200

For detailed information on Application Tooling please refer to our Main Catalogue or the Internet.



Cable Ties with punch-locking mechanism

- **MST-Series, Stainless Steel 304**

Stainless steel cable ties are designed for fixing loads and cables securely in hazardous industrial environments such as railway carriages, jet engines, inside power plants or on offshore drilling platforms, where exposure to extremes of weather, saltwater and temperature are common. The MST-Series tie with its new punch-locking mechanism is an excellent choice especially for environments which require high resistance to vibrations.

Features and Benefits

- MST-Series cable ties are made from stainless steel 304
- No loosening after bundling
- Corrosion and weather resistant
- Significantly improved vibration resistance
- Outstanding chemical resistance
- Space saving solution
- Safe cut-off (no sharp edges)
- Antimagnetic
- High temperature resistant
- Non-burning



Stainless Steel Cable Ties MST-Series.

MATERIAL	Stainless Steel (SS304)
Operating Temperature	-80 °C to +538 °C
Flammability	Non burning
Specifications	Det Norske Veritas

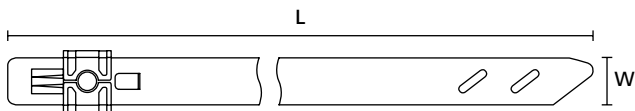

MST tie

TYPE	Width (W)	Length (L)	Bundle Ø min.	Bundle Ø max.		Material	Pack Cont.	Application Tool No.	Article-No.
MST200S	5.9	207.0	5.0	50.0	900	SS304	100 pcs.	19	111-01549
MST360S	5.9	360.0	5.0	100.0	900	SS304	100 pcs.	19	111-01550
MST500S	5.9	500.0	5.0	145.0	900	SS304	100 pcs.	19	111-01551
MST700S	5.9	700.0	5.0	205.0	900	SS304	100 pcs.	19	111-01552
MST360M	8.9	369.0	8.0	100.0	1,500	SS304	50 pcs.	20	111-01631
MST500M	8.9	509.0	8.0	145.0	1,500	SS304	50 pcs.	20	111-01632
MST700M	8.9	700.0	8.0	205.0	1,500	SS304	50 pcs.	20	111-01633

All dimensions in mm. Subject to technical changes.

Minimum Order Quantity (MOQ) may differ from package content. Other packaging options may also be available.

Application Tool No.	
19	20
MST6	MST9

For detailed information on Application Tooling please refer to our Main Catalogue or the Internet.



One Step to the Web!

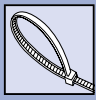

Cable Ties for higher chemical resistance and for temperatures up to +170 °C in Ethylene Tetrafluoroethylene

- **T-Series in E/TFE (Tefzel®)**

T-Series cable ties for bundling and securing cables, pipes and hoses. These cable ties can be used for nearly all kinds of applications, especially when a high chemical resistance is required.

Features and Benefits

- Blue higher chemical resistance cable tie available in a wide range sizes
- Made from 100% high quality plastic, allows for good recycling
- Inside serration for a strong hold onto bundles
- Easy application either manually or with a processing tool
- Simple to insert due to bent tail
- High temperature resistance
- No moisture absorption



MATERIAL	Ethylene Tetrafluoroethylene (E/TFE)
Operating Temperature	-80 °C to +170 °C
Flammability	UL94 V0

RoHS ✓

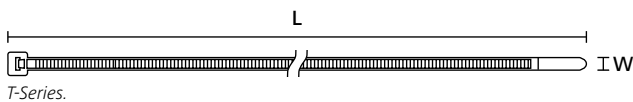

TYPE	Width (W)	Length (L)	Bundle Ø max.	N	Material	Colour	Pack Cont.	Tools	Article-No.
T18R	2.5	100.0	22.0	80	E/TFE	Blue (BU)	100 pcs.	2;4-6	111-00659
T30R	3.5	150.0	36.0	133	E/TFE	Blue (BU)	100 pcs.	2;4-6	111-00698
T50R	4.7	201.0	50.0	222	E/TFE	Blue (BU)	100 pcs.	2-10	111-00732
T50L	4.7	382.0	105.0	222	E/TFE	Blue (BU)	100 pcs.	2-10	111-00718
T120R	7.4	387.0	105.0	535	E/TFE	Blue (BU)	50 pcs.	3;9-12	111-01125

All dimensions in mm. Subject to technical changes.

Minimum Order Quantity (MOQ) may differ from package content. Other packaging options may also be available. General linguistic usage for cable ties made from raw material E/TFE is Tefzel®-Tie. In addition to Tefzel® from DuPont HellermannTyton is also using equivalent E/TFE raw material from other suppliers.

Application Tool No.									
2	3	4	5	6	7	8	9	10	11
MK20	MK21	MK3SP	MK3PNSP2	EVO7	MK7HT	MK7P	MK6	MK9	MK9HT

For detailed information on Application Tooling please refer to our Main Catalogue or the Internet.

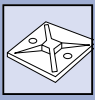

Cable Ties and Fixings

Cable Tie Mounts

Screw Fixing Mounts

- **KR-E/TFE for a broad temperature range**

Designed specifically for holding heavier cable bundles these mounting bases can be used in many industries from Agriculture to Truck manufacture, they offer a very secure fixing and can be used with a wide variety of heavy duty cable ties up to 7.6 mm wide.

Features and Benefits

- Curved design for additional cable support
- Simple to install with a screw or bolt
- Excellent security, particularly in areas of high vibration

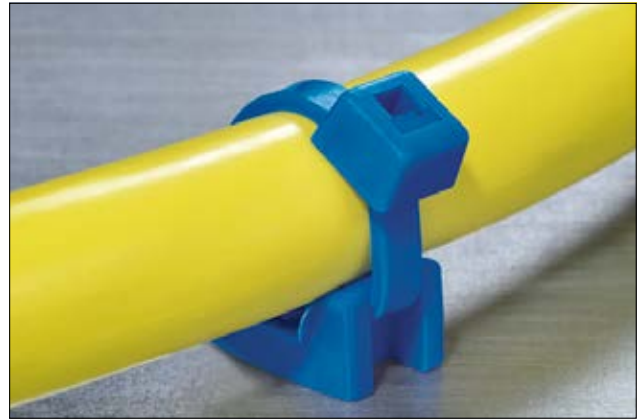

Fixing Tie Mount KR6G5-E/TFE.



The KR Screw Fixing Mounts made of E/TFE can ideally be used with the T-Series in E/TFE, please see page 25.

MATERIAL	Ethylene Tetrafluoroethylene (E/TFE)
Operating Temperature	-80 °C to +170 °C
Flammability	UL94 V0

RoHS ✓

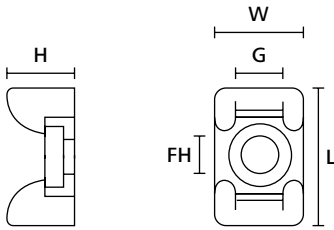

Cable Tie Mounts KR6G5, KR8G5 and CTM

TYPE	Width (W)	Length (L)	Height (H)	Hole Ø (FH)	Strap Width max. (G)	Material	Colour	Pack Cont.	Article-No.
KR6G5	11.8	17.8	8.8	4,5	6.4	E/TFE	Blue (BU)	100 pcs.	151-00653
KR8G5	14.3	24.8	12.1	6,5	8.3	E/TFE	Blue (BU)	100 pcs.	151-00654

All dimensions in mm. Subject to technical changes.

Minimum Order Quantity (MOQ) may differ from package content. Other packaging options may also be available.

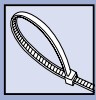

Cable Ties for higher chemical resistance for temperatures up to +115°C in Polypropylene

- **T-Series in PP**

These cable ties are used for routing, bundling and securing cables, pipes and hoses.

Features and Benefits

- Higher chemical resistant cable tie available in a wide range sizes
- Made from 100% high quality plastic, allows for good recycling
- Inside serration for a strong hold around bundles
- Easy application either manually or with a processing tool
- Simple to insert due to the ergonomically bent tail
- Floats in water
- High chemical resistance



T-Series.

MATERIAL	Polypropylene (PP)
Operating Temperature	-40 °C to +115 °C
Flammability	UL94 HB

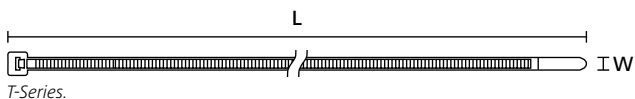

T-Series.

TYPE	Width (W)	Length (L)	Bundle Ø max.	N	Material	Colour	Pack Cont.	Tools	Article-No.
T18R	2.5	100.0	22.0	36	PP	Black (BK)	100 pcs.	2;4-6	111-01917
	2.5	100.0	22.0	36	PP	Natural (NA)	1,000 pcs.	2;4-6	111-01922
T30R	3.6	148.0	32.0	89	PP	Natural (NA)	100 pcs.	2;4-6	111-03017
T50R	4.8	202.0	44.5	111	PP	Black (BK)	100 pcs.	2-10	111-04928
	4.8	202.0	44.5	111	PP	Natural (NA)	100 pcs.	2-10	111-04931
T120S	7.6	225.0	55.0	267	PP	Black (BK)	500 pcs.	3;9-12	111-12827
T120R	7.6	390.0	105.0	267	PP	Black (BK)	500 pcs.	3;9-12	111-12066

All dimensions in mm. Subject to technical changes.

Minimum Order Quantity (MOQ) may differ from package content. Other packaging options may also be available.

Application Tool No.									
2	3	4	5	6	7	8	9	10	11
MK20	MK21	MK3SP	MK3PNSP2	EVO7	MK7HT	MK7P	MK6	MK9	MK9HT

For detailed information on Application Tooling please refer to our Main Catalogue or the Internet.

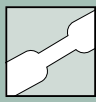

Heat Shrinkable Tubing 2:1 - PVDF

- TK20

Typical applications of this translucent tubing are where high-temperature performance is required. Also very suitable for applications that ask for visual inspection of covered components, or if a low friction surface is needed. TK20 is also used as oil stop for energy cables.

This thin walled, translucent heat shrink tubing is often used for chemical applications.

Features and Benefits

- Semi-rigid heat shrinkable tubing made of PVDF
- Thin walled and tough
- For higher temperature applications
- Very good mechanical strength, abrasion resistance and chemical resistance
- Meets various industrial standards
- Self extinguishing, UL 224 VW1 listed



This thin walled, translucent heat shrink tubing is often used for chemical applications.

MATERIAL	Polyvinylidene Fluoride (PVDF)
Shrink Ratio	2:1
Operating Temperature	-55 °C to +175 °C
Minimum Shrink Temperature	+175 °C
Longitudinal change after shrinkage	+/-10% max
Dielectric Strength	≥ 30 kV/mm min. according to ASTM D2171
Flammability	UL224 VW-1
Specifications	SAE - AMS - DTL-23053 / 8, UL224 150 °C 600V VW-1, VG 95343



Heat Shrinkable Tubing 2:1



TYPE	Supplied Ø D min.	Recov. Ø d max.	Wall (WT)	Length (L)	Colour	Designation as per VG-Norm	Article-No.
TK20-1.2/0.6	1.2	0.6	0.25	1.2 m	Transparent (CL)	VG95343T05F001M	331-00129
TK20-1.6/0.8	1.6	0.8	0.25	1.2 m	Transparent (CL)	VG95343T05F002M	311-00169
TK20-2.4/1.2	2.4	1.2	0.25	1.2 m	Transparent (CL)	VG95343T05F003M	311-00249
TK20-3.2/1.6	3.2	1.6	0.25	1.2 m	Transparent (CL)	VG95343T05F004M	311-00329
TK20-4.8/2.4	4.8	2.4	0.25	1.2 m	Transparent (CL)	VG95343T05F005M	311-00489
TK20-6.4/3.2	6.4	3.2	0.30	1.2 m	Transparent (CL)	VG95343T05F006M	311-00649
TK20-9.5/4.8	9.5	4.8	0.30	1.2 m	Transparent (CL)	VG95343T05F007M	311-00959
TK20-12.7/6.4	12.7	6.4	0.30	1.2 m	Transparent (CL)	VG95343T05F008M	311-01279
TK20-19.1/9.5	19.1	9.5	0.43	1.2 m	Transparent (CL)	VG95343T05F009M	311-01909
TK20-25.4/12.7	25.4	12.7	0.48	1.2 m	Transparent (CL)	VG95343T05F010M	311-02549
TK20-38.1/19.1	38.1	19.1	0.51	1.2 m	Transparent (CL)	-	311-03819
TK20-50.8/25.4	50.8	25.4	0.51	1.2 m	Transparent (CL)	-	311-05089

All dimensions in mm. Subject to technical changes.
Minimum Order Quantity (MOQ) may differ from package content.



Please note! Not all products listed on this page may have this approval.

Heat Shrinkable Tubing 2:1 - PVDF

- TK29

Typical applications of this translucent tubing are where high-temperature performance is required. Also very suitable for applications that ask for visual inspection of covered components, or if low friction surface is needed. TK29 is also used as oil stop for energy cables.

This thin walled, translucent heat shrink tubing is often used for chemical applications.

Features and Benefits

- Transparent, semi-flexible heat shrinkable tubing
- Very thin walled and tough
- Self extinguishing
- For higher temperature applications
- Very good mechanical strength and chemical resistance
- Meets lots of industrial standards
- Supplied on reel

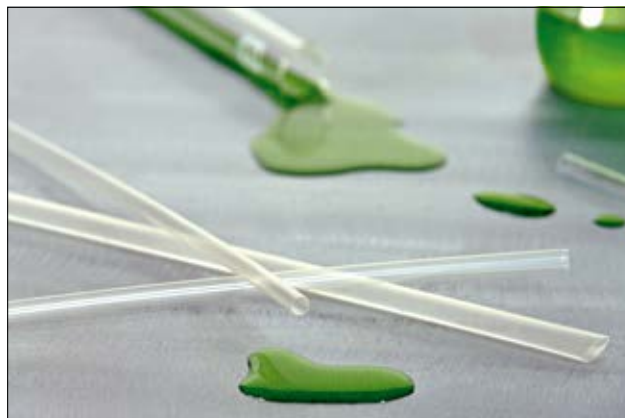

TK29 thin walled, translucent heat shrink tubing on reel.

MATERIAL	Polyvinylidene Fluoride (PVDF)
Shrink Ratio	2:1
Operating Temperature	-55 °C to +175 °C
Minimum Shrink Temperature	+150 °C
Longitudinal change after shrinkage	+/-10% max
Dielectric Strength	≥ 30 kV/mm min. according to ASTM D2171
Flammability	UL224 VW-1
Specifications	MIL-DTL-23053, UL224 VW-1

RoHS ✓



TYPE	Supplied Ø D min.	Recov. Ø d max.	Wall (WT)	Reel Length	Colour	Article-No.
TK29-1.2/0.6	1.2	0.6	0.25	300 m	Transparent (CL)	311-90129
TK29-1.6/0.8	1.6	0.8	0.25	300 m	Transparent (CL)	311-90169
TK29-2.4/1.2	2.4	1.2	0.25	150 m	Transparent (CL)	311-90249
TK29-3.2/1.6	3.2	1.6	0.25	150 m	Transparent (CL)	311-90329
TK29-4.8/2.4	4.8	2.4	0.25	60 m	Transparent (CL)	311-90489
TK29-6.4/3.2	6.4	3.2	0.30	60 m	Transparent (CL)	311-90649
TK29-9.5/4.8	9.5	4.8	0.30	60 m	Transparent (CL)	311-90959
TK29-12.7/6.4	12.7	6.4	0.30	60 m	Transparent (CL)	311-91279
TK29-19.1/9.5	19.1	9.5	0.43	60 m	Transparent (CL)	311-91909
TK29-25.4/12.7	25.4	12.7	0.48	60 m	Transparent (CL)	311-92549
TK29-38.1/19.1	38.1	19.1	0.51	60 m	Transparent (CL)	311-93819
TK29-50.8/25.4	50.8	25.4	0.51	60 m	Transparent (CL)	311-95089

All dimensions in mm. Subject to technical changes.
Minimum Order Quantity (MOQ) may differ from package content.



Please note! Not all products listed on this page may have this approval.



Heat Shrinkable Tubing - PTFE

- TFE2 2:1

TFE is ideal for high temperature applications, when resistance to aggressive fluids is required or a very thin walled tubing is needed, for example in pH-measuring instruments. TFE tubing is also used to reduce movement due to friction, covering cylinders for example.

Features and Benefits

- PTFE heat shrink tubing
- Very high temperature resistance
- Extra thin wall translucent tubing
- High abrasion resistance and good resistance against aggressive chemicals
- Available in either 2:1 (TFE2) or 4:1 (TFE4) shrink ratios



TFE is available in either 2:1 or 4:1 shrink ratios.

MATERIAL	Polytetrafluoroethylene (PTFE)
Operating Temperature	-70 °C to +260 °C
Minimum Shrink Temperature	+350 °C
Longitudinal change after shrinkage	-20% max.
Dielectric Strength	40 kV/mm according to DIN 53481
Flammability	Non burning



Heat Shrinkable Tubing 2:1

TYPE	Supplied Ø D min.	Recov. Ø d max.	Wire Size (AWG)	Wall (WT)	Length (L)	Colour	Shrink Ratio	Article-No.
TFE2-30	0.86	0.38	30	0.23	1.2 m	Transparent (CL)	2:1	336-00079
TFE2-28	0.96	0.46	28	0.23	1.2 m	Transparent (CL)	2:1	336-00099
TFE2-26	1.17	0.56	26	0.23	1.2 m	Transparent (CL)	2:1	336-00109
TFE2-24	1.27	0.69	24	0.25	1.2 m	Transparent (CL)	2:1	336-00139
TFE2-22	1.39	0.82	22	0.25	1.2 m	Transparent (CL)	2:1	336-00149
TFE2-20	1.52	0.99	20	0.30	1.2 m	Transparent (CL)	2:1	336-00159
TFE2-18	1.93	1.25	18	0.30	1.2 m	Transparent (CL)	2:1	336-00199
TFE2-16	2.36	1.55	16	0.30	1.2 m	Transparent (CL)	2:1	336-00249
TFE2-14	3.05	1.83	14	0.30	1.2 m	Transparent (CL)	2:1	336-00319
TFE2-12	3.81	2.26	12	0.30	1.2 m	Transparent (CL)	2:1	336-00399
TFE2-10	4.85	2.85	10	0.30	1.2 m	Transparent (CL)	2:1	336-00489
TFE2-8	6.10	3.58	8	0.38	1.2 m	Transparent (CL)	2:1	336-00619
TFE2-6	7.67	4.52	6	0.38	1.2 m	Transparent (CL)	2:1	336-00779
TFE2-4	9.40	5.69	4	0.38	1.2 m	Transparent (CL)	2:1	336-00949
TFE2-2	10.92	7.06	2	0.38	1.2 m	Transparent (CL)	2:1	336-01109
TFE2-0	11.94	8.81	0	0.38	1.2 m	Transparent (CL)	2:1	336-01209

All dimensions in mm. Subject to technical changes.

AWG: American Wire Gauge Minimum Order Quantity (MOQ) may differ from package content.



• TFE4 4:1



Heat Shrinkable Tubing 4:1

TYPE	Supplied Ø D min.	Recov. Ø d max.	Size (imperial)	Wall (WT)	Length (L)	Colour	Shrink Ratio	Article-No.
TFE4-5/64	1.98	0.64	5/64 "	0.22	1.2 m	Transparent (CL)	4:1	339-00209
TFE4-1/8	3.17	0.94	1/8 "	0.25	1.2 m	Transparent (CL)	4:1	339-00329
TFE4-3/16	4.75	1.27	3/16 "	0.30	1.2 m	Transparent (CL)	4:1	339-00340
TFE4-1/4	6.35	1.60	1/4 "	0.30	1.2 m	Transparent (CL)	4:1	339-00649
TFE4-3/8	9.52	2.44	3/8 "	0.30	1.2 m	Transparent (CL)	4:1	339-00959
TFE4-1/2	12.70	3.66	1/2 "	0.38	1.2 m	Transparent (CL)	4:1	339-01279
TFE4-5/8	15.87	4.52	5/8 "	0.38	1.2 m	Transparent (CL)	4:1	339-01599
TFE4-3/4	19.05	5.69	3/4 "	0.38	1.2 m	Transparent (CL)	4:1	339-01909
TFE4-1	25.40	7.06	1 "	0.38	1.2 m	Transparent (CL)	4:1	339-02549
TFE4-1 1/4	31.75	8.82	1 "	0.38	1.2 m	Transparent (CL)	4:1	339-03189

All dimensions in mm. Subject to technical changes.
Minimum Order Quantity (MOQ) may differ from package content.



Cable Protection Systems

Protective Tubing and Spiral Binding

Metal-Content Cable Cover

- **Helawrap HWPPMC**

HWPPMC is particularly suitable for installation and maintenance for food-processing machines and in food-processing plants.

Features and Benefits

- High metal-content for reliable detection with standard detection equipment
- Quick and effortless to apply
- Stainless steel preserves resistance to corrosion
- Blue colour for enhanced visibility
- Ideal solution for bundling and protecting cables and hoses
- Highly flexible
- Very good abrasion protection
- Special profile enables branching off cable at any point
- Can be removed and reused
- Handy applicator tool included

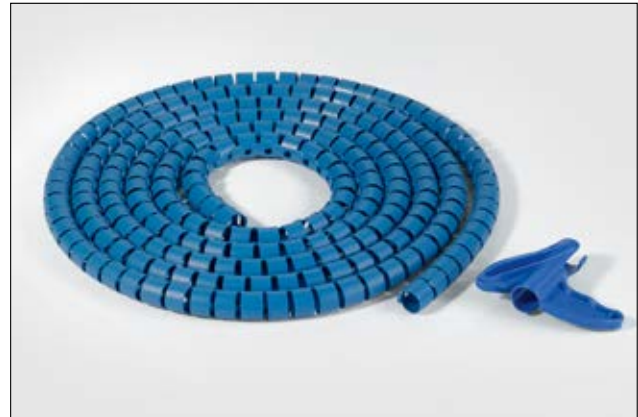

HWPPMC metal-content cable cover.

MATERIAL	Polypropylene (PP), Stainless Steel (SS)
Operating Temperature	-60 °C to +100 °C, intermittent +140 °C
Flammability	UL94 HB
Specifications	FDA, HACCP



Insert one or more cables into the insertion slot of the applicator tool.



Place the applicator tool in one end of the Helawrap cable cover.



Simply slide the applicator tool through the Helawrap cover.

TYPE	Bundle Ø max.	Colour	Reel Length	Application Tool	Article-No.
HWPPMC8	9.0	Blue (BU)	25 m	HAT8	161-66000
HWPPMC16	16.0	Blue (BU)	25 m	HAT16	161-66100
HWPPMC20	21.0	Blue (BU)	25 m	HAT20	161-66200
HWPPMC25	27.0	Blue (BU)	25 m	HAT25	161-66300
HWPPMC30	32.0	Blue (BU)	25 m	HAT30	161-66400

All dimensions in mm. Subject to technical changes.
Minimum Order Quantity (MOQ) may differ from package content.

HACCP stands for Hazard Analysis Critical Control Points. It is a method of identifying and eliminating potential hazards in food production. Those hazards that cannot be eliminated are controlled in such a way that the consumer is protected. These controls are known as Critical Control Points (CCPs). They are CRITICAL because if they fail or are not carried out, the risk of the product harming the customer, increases.

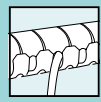

Metal-Content Spiral Binding

- SBPEMC

SBPEMC is designed for applications in food-processing plants and machines.

Features and Benefits

- High metal-content for reliable detection with standard detection equipment
- Stainless steel preserves resistance to corrosion
- Blue colour for enhanced visibility
- Ideal solution for bundling and protecting cables and hoses
- Highly flexible
- Suitable for retro-fitting
- Branching off cable at any point



SBPEMC metal-content spiral binding.



One Step to the Web!



Detectable, metal-content spiral binding protects cables on food-processing machines.

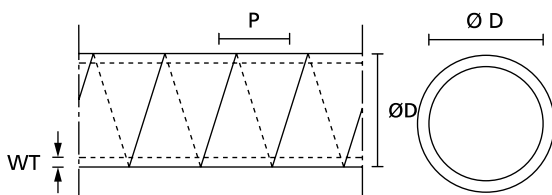

MATERIAL	Polyethylene (PE), Stainless Steel (SS)
Operating Temperature	-60 °C to +80 °C, intermittent +120 °C
Flammability	UL94 HB
Specifications	FDA, HACCP



TYPE	Wall (WT)	Pitch (P)	Bundle Ø min.	Bundle Ø max.	Colour	Reel Length	Article-No.
SBPEMC1.5	0.80	6.0	1.6	8.0	Blue (BU)	30 m	161-46000
SBPEMC16	1.00	7.8	20.0	150.0	Blue (BU)	30 m	161-46300
SBPEMC4	1.40	12.5	5.0	20.0	Blue (BU)	30 m	161-46100
SBPEMC9	1.60	16.0	10.0	100.0	Blue (BU)	30 m	161-46200

All dimensions in mm. Subject to technical changes.
Minimum Order Quantity (MOQ) may differ from package content.

HACCP stands for Hazard Analysis Critical Control Points. It is a method of identifying and eliminating potential hazards in food production. Those hazards that cannot be eliminated are controlled in such a way that the consumer is protected. These controls are known as Critical Control Points (CCPs). They are CRITICAL because if they fail or are not carried out, the risk of the product harming the customer, increases.

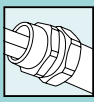

Cable Protection Systems

Spiral-Reinforced Conduit Systems

Spiral-reinforced PVC Conduits

- **PSRSC Conduit**

Machine building, plant construction, shipbuilding, automation, electrical installations

Features and Benefits

- Flexible
- Easy to clean outside surface
- Withstands some torsional movement
- Self-extinguishing
- Easy to feed cables
- Can be used with PSR PA66 fittings and PSRSC metal fittings
- Colour: black; light grey, orange (highly flexible), green (oil resistant), blue (high temperature resistant) upon request

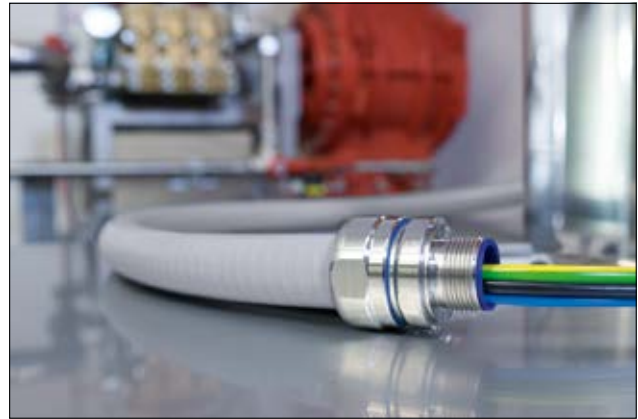

HelaGuard PSRSC conduit and PSRSC-FMCSSFF stainless steel fittings: an easy-to-easy cable protection system for food-processing applications.

MATERIAL	Polyvinylchloride (PVC)
Operating Temperature	-5 °C to +70 °C
Flammability	self-extinguishing according to EN IEC 61386

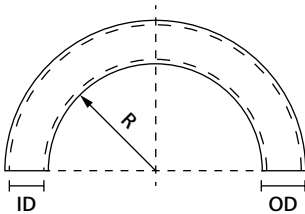

HelaGuard spiral-reinforced conduit, smooth outer coating

TYPE	Nominal Ø	Outside Ø (OD)	Inside Ø (ID)	Bending Radius (R)	Weight (g/m)	Reel Length	Colour	Article-No.
PSRSC16	16	17.8	12.0	50	139	30 m	Grey (GY)	166-40302
PSRSC20	20	21.1	16.0	70	174	30 m	Grey (GY)	166-40303
PSRSC25	25	26.4	21.0	90	235	30 m	Grey (GY)	166-40304
PSRSC32	32	33.1	26.5	140	327	30 m	Grey (GY)	166-40305
PSRSC40	40	41.8	35.4	190	448	30 m	Grey (GY)	166-40306
PSRSC50	50	47.9	40.0	240	725	30 m	Grey (GY)	166-40307
PSRSC63	63	59.7	51.3	270	948	30 m	Grey (GY)	166-40308

All dimensions in mm. Subject to technical changes.
Minimum Order Quantity (MOQ) may differ from package content.



Fittings for spiral-reinforced PVC conduits

- PSRSC-FMCFSS compression fitting for food-processing applications

Straight fitting, external thread, stainless steel (SS316).

Fulfils IP66, IP67, IP68 and IP69k with PSRSC conduits.

Features and Benefits

- Multipart stainless steel (SS316) compression fitting including elastomeric seal
- Rounded edges, smooth surfaces and no crevices where food or other substances can collect or bacteria grow
- Can be used for knockouts or threaded entries as fitting rotates until tightened
- Fits PSRSC conduits



HelaGuard PSRSC-FMCFSS stainless steel fittings for applications in the food-processing industry.

MATERIAL	Stainless Steel (SS316), Nickel Plated Brass (NPB), Polyamide 6 (PA6)
Operating Temperature	-50 °C to +135 °C
Specifications	EN 1672-2, EN ISO 14155

RoHS ✓

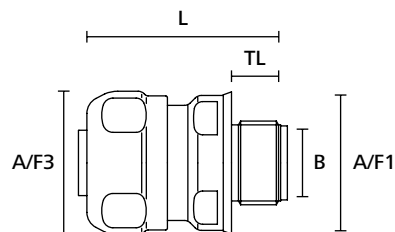

HelaGuard compression fitting, straight with fixed external thread

TYPE	Thread Size (metric)	Min. Bore Size (B)	Length (L)	A/F Body (A/F1)	A/F Nut (A/F3)	Thread Length (TL)	Pack Cont.	Colour	Article-No.
PSRSC16-FMCFSS-M16	M16	10.7	46.0	27	29	10	1 pcs.	Metal (ML)	166-41601
PSRSC20-FMCFSS-M20	M20	14.5	49.3	30	32	12	1 pcs.	Metal (ML)	166-41602
PSRSC25-FMCFSS-M25	M25	18.7	53.7	36	38	14	1 pcs.	Metal (ML)	166-41603
PSRSC32-FMCFSS-M32	M32	24.6	53.7	42	45	15	1 pcs.	Metal (ML)	166-41604
PSRSC40-FMCFSS-M40	M40	32.7	58.4	52	55	16	1 pcs.	Metal (ML)	166-41605
PSRSC50-FMCFSS-M50	M50	37.7	63.0	59	62	16	1 pcs.	Metal (ML)	166-41606

All dimensions in mm. Subject to technical changes.
Minimum Order Quantity (MOQ) may differ from package content.



Please note! Not all products listed on this page may have this approval.

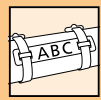

Stainless Steel Printing System

• M-BOSS Compact

M-BOSS Compact is a quiet easy-to-use metal plate embossing printer with a small production footprint. It is simple to install and operate and only needs a standard electrical supply and a PC. Texts are created with Tagprint Pro 3.0. Simply open the easy to use program to create print lists.

Improved cooling system now ensures a continuous operation between 8-10 hours.

Marker plates are attached to pipes and cables using 4.6 mm width MBT cable ties and a MK9SST hand tool.

Features and Benefits

- Small and easy to use metal plate embosser
- Quiet embossing mechanism suited to production and office environments
- Emboss first marker within a minute of power up
- Embossed characters have been tested to withstand 1.5 million strikes each
- Improved cooling systems allows 8-10 hours continuous printing
- Use Tagprint Pro 3.0 labelling software with pre-loaded templates to simplify print jobs
- Powered by a standard electrical supply
- Organiser is available to manage printed output (UNS: 544-21000), increases printer weight to 45kg
- Printer is delivered with the following 45 piece 4mm character set:
- Letters: A B C D E F G H I J K L M N O P Q R S T U V W X Y Z
- Numbers: 0 1 2 3 4 5 6 7 8 9
- Symbols: & - / . , ' Ä, Ö, Ü

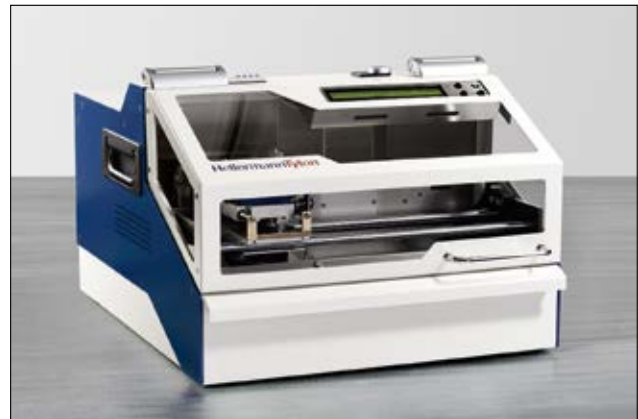

A quiet, durable, and easy to use metal plate embossing printer.

Print Method	Embossed
Power Supply	110 Volt AC- 240 Volt AC 50/60 Hz
Cycle Time	1 second per character
Printer Interfaces	USB 2.0
System Requirements	MS Windows XP, W7
Dimensions W x H x D	480 mm x 360 mm x 570 mm
Weight	41 kg
Specifications	CE



TYPE	Pack Cont.	Article-No.
M-BOSS Compact	1 pcs.	544-20000

All dimensions in mm. Subject to technical changes. Minimum Order Quantity (MOQ) may differ from package content. Other packaging options may also be available.

1.5 million strikes per character without maintenance



• M-BOSS Compact and Organiser

M-BOSS Compact and Organiser system gives the added advantage of a self-contained storage system within the print unit.

The organiser is a 10 container carousel storage system that can be programmed to hold either an individual or a pre-defined set of marker plates. This means that users have the flexibility to manage how they work with the printed output. A simple input screen on the top of the machine is used to specify the quantity per container within the carousel. The carousel drawer when opened extends 430mm from the front of the printer.

Features and Benefits

- Ability to manage how the printed marker plates are organised
- Carousel system under the printer has 10 removable marker plate containers
- Flexible output means all marker plates or a set amount can be sent to each container
- Carousel system will hold up to 400 markers
- Each container can hold 40 marker plates



A simple solution to managing your printer output.

TYPE	Pack Cont.	Article-No.
M-BOSS Compact and Organiser	1 pcs.	544-21000

All dimensions in mm. Subject to technical changes. Minimum Order Quantity (MOQ) may differ from package content. Other packaging options may also be available.

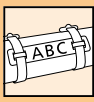

Stainless Steel Printing System

- **M-BOSS Compact Markers**

M-BOSS Markers are used in all areas where severe mechanical or chemical conditions occur e.g. offshore industry, marine engineering, petrochemical industry, mining, underground or on radio and cellular masts where mark permanence is critical.

The raised surface of the embossed print ensures that the text remains visible even with dirt, grease, and paint cover the marker. The physical characteristics of the metal and the height of the embossed mark allows users to apply a stiff or metallic brush to the surface and remove excess layers of paint or grease without damaging the integrity of the text.

Features and Benefits

- Raised marking ensure text visibility even when covered in dust, debris, grease and oil
- Stainless steel grade SS316 is suited for use in harsh environments
- Marker plates are designed for use with stainless steel cable ties with a 4.6 mm strap width
- Apply ties with a MK9SST

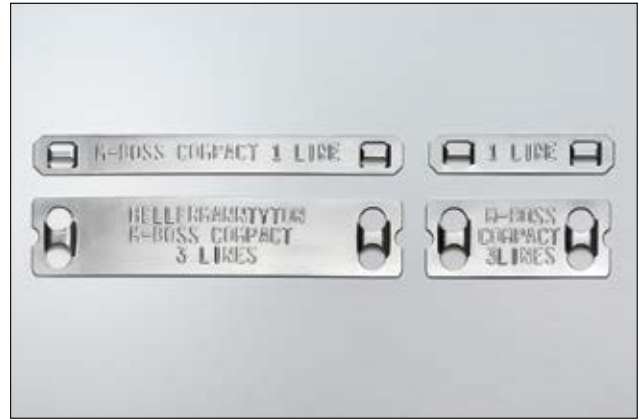
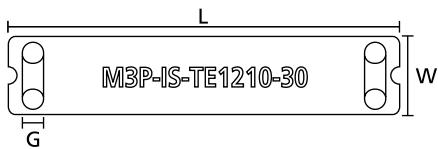

A range of metal plate sizes to suit your needs.

MATERIAL	Stainless Steel (SS316)
Operating Temperature	-80 °C to +538 °C



TYPE	Strap Width max. (G)	Number of lines	Characters per line	Number of characters	Width (W)	Length (L)	Pack Cont.	Article-No.
MBML10X45	4.6	1	8	8	10.0	45.0	1,000	544-80101
MBML10X90	4.6	1	23	23	10.0	90.0	500	544-80102
MBML20X45	4.6	3	8	24	20.0	45.0	1,000	544-80201
MBML20X90	4.6	3	23	69	20.0	90.0	500	544-80202

All dimensions in mm. Subject to technical changes. Minimum Order Quantity (MOQ) may differ from package content. Other packaging options may also be available.



Identification for hazardous environments: M-BOSS Compact stainless steel markers.



One Step to the Web!

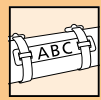

Stainless Steel Printing System

- M-BOSS Print Service**

Customised embossed stainless steel SS316 markers are now available. Simply send required texts electronically for perfect embossed markers.

Characters are embossed so that dirt, dust, paint and debris can be removed leaving a clear visible mark.

MBC marker plates are designed with a high bridge that allows both plastic and metal cable ties; metal ties up to 7.9mm wide and 0.27mm thick, and plastic ties up to 4.6mm wide and 1.5mm thick.

The MBML range of marker plates can only be used with metal ties up to 4.6mm wide.

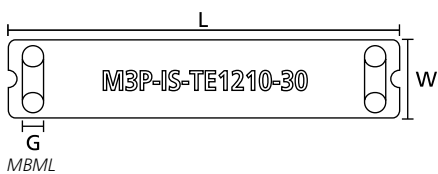
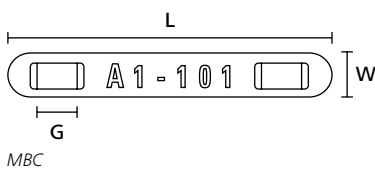

M-BOSS markers remain visible in areas of dirt, grease and paint.

MATERIAL	Stainless Steel (SS316)
Operating Temperature	-80 °C to +538 °C

HF ✓

LFH ✓

RoHS ✓

TYPE	Strap Width max. (G)	Number of lines	Characters per line	Number of characters	Width (W)	Length (L)	Pack Cont.	Article-No.
MBMLE-DE10X45	4.6	1	8	8	10.0	45.0	10	544-80103
MBMLE-DE10X90	4.6	1	23	23	10.0	90.0	10	544-80104
MBMLE-DE20X45	4.6	3	8	24	20.0	45.0	10	544-80203
MBMLE-DE20X90	4.6	3	23	69	20.0	90.0	10	544-80204
MBCE-DE10X60	8.0	1	10	10	10.0	60.0	10	540-10048
MBCE-DE10X80	8.0	1	15	15	10.0	80.0	10	540-10049
MBCE-DE10X100	8.0	1	20	20	10.0	100.0	10	540-10003
MBCE-DE14X100	8.0	2	20	40	14.0	100.0	10	540-10050

All dimensions in mm. Subject to technical changes. Minimum Order Quantity (MOQ) may differ from package content. Other packaging options may also be available.

- Laser Beam Marked Metal Plates and Ties**

Customised stainless steel SS316 markers are now available. Simply send required texts, barcodes, and logos electronically for perfect laser etched marker plates.

- Excellent character legibility
- Resistant to weathering and extreme levels of UV light
- Printed mark will last the lifetime of the metal plate and cable tie
- MBC or MBML marker plates are possible





Manual Tensioning Tool Plastic Housing

- EVO7 up to 4.8 mm strap width

Features and Benefits

- Ergonomic, slip-proof handle for a comfortable and secure grip
- Extremely low maintenance
- Fast and precise application with minimum effort (TLC mechanism)
- Convenient and simple tension adjustment
- Extended, slim nose for use in narrow spaces
- Housing made of resilient and lightweight glass fibre-reinforced polyester
- Standard grip span (90 mm) and short grip span (80 mm) available



EVO7.

TYPE	Description	Strap Width max. (G)	Strap Thickness max.	Weight	Article-No.
EVO7	EVO7	4.8	1.5	277 g	110-70129
EVO7SP	EVO7SP	4.8	-	278 g	110-70130
BLADEKT	Blade-Kit	-	-	-	110-70106

All dimensions in mm. Subject to technical changes.

TLC-Technology: Tension - Lock - Cut

The new EVO7 protects muscles and joints and increases effectiveness

- Less recoil shock reduces impact to the operator's hand
- Application of force is significantly reduced



Application video: EVO7



1. Tension: Tie is tensioned as usual.

2. Lock: When the desired tension is met the locking mechanism locks the tie in place.



3. Cut: Innovative, effortless and less recoil shock cut-off function.



Manual Tensioning Tool with Plastic Housing

- MK9 up to 13.5 mm strap width

MK9 tool is used to apply bigger cable ties as they are used in trucks and busses. MIL and VG certification allows the use of MK9 for military vehicle and aviation construction.

Features and Benefits

- Glass-fibre-reinforced housing
- Ergonomic design
- For HellermannTyton plastic cable ties up to 13.5 mm width
- Consistent tensioning and automatically flush cutting
- Infinitely adjustable tension force combined with two-step quick adjustment
- MIL and VG approved



MK9.

TYPE	Description	Strap Width max. (G)	Strap Thickness max.	Weight	Article-No.
MK9	MK9.9A	13.5	2.0	0.385 kg	110-09500
Replacement Blade	GUNPART.9AA	-	-	0.01 kg	110-09511
Lock cap tensioning knob	Lock cap tensioning knob	-	-	0.011 kg	110-07200

All dimensions in mm. Subject to technical changes.

Manual Tensioning Tool for Metal Ties MBT-Series

- MK9SST up to 16.0 mm strap width

Features and Benefits

- Glass-fibre-reinforced housing
- Ergonomic design
- Consistent tensioning and automatically cutting of metal ties MBT-series
- Infinitely adjustable tension force combined with two-step quick adjustment



MK9SST.

TYPE	Description	Strap Width max. (G)	Strap Thickness max.	Weight	Article-No.
MK9SST	MK9SST.9A	16.0	0.3	0.6 kg	110-95000
Replacement Blade	Replacement Blade	-	-	0.01 kg	110-95273

All dimensions in mm. Subject to technical changes.



Please note! Not all products listed on this page may have this approval.

Expertise worldwide – you will find your local contact here:

Europe

 **HellermannTyton GmbH – Austria**
Rennbahnweg 65
1220 Vienna
Tel: +43 12 59 99 55-0
Fax: +43 12 59 99 11
E-Mail: office@HellermannTyton.at
www.HellermannTyton.at

 **HellermannTyton – Czech Republic**
E-Mail: officeCZ@HellermannTyton.at
www.HellermannTyton.cz

 **HellermannTyton – Denmark**
Industrivej 44A, 1.
4000 Roskilde
Tel: +45 702 371 20
Fax: +45 702 371 21
E-Mail: htdk@HellermannTyton.dk
www.HellermannTyton.dk

 **HellermannTyton – Finland**
Sähkötie 8
01510 Vantaa
Tel: +358 9 8700 450
Fax: +358 9 8700 4520
E-Mail: myynti@HellermannTyton.fi
www.HellermannTyton.fi

 **HellermannTyton S.A.S. – France**
2 rue des Hêtres, C.S. 80543
78197 Trappes Cedex
Tel: +33 1 30 13 80 00
Fax: +33 1 30 13 80 60
E-Mail: info@HellermannTyton.fr
www.HellermannTyton.fr

 **HellermannTyton GmbH – Germany**
Großer Moorweg 45
25436 Tornesch
Tel: +49 4122 701-0
Fax: +49 4122 701-400
E-Mail: info@HellermannTyton.de
www.HellermannTyton.de

 **HellermannTyton KFT – Hungary**
Kisfaludy u. 13
1044 Budapest
Tel: +36 1 369 4151
Fax: +36 1 369 4151
E-Mail: officeHU@HellermannTyton.at
www.HellermannTyton.hu

 **HellermannTyton Ltd – Ireland**
Unit 77 Cherry Orchard
Industrial Estate
Ballyfermot, Dublin 10
Tel: +353 1 626 8267
Fax: +353 1 626 8022
E-Mail: sales@HellermannTyton.ie
www.HellermannTyton.co.uk

 **HellermannTyton S.r.l. – Italy**
Via Visco, 3/5
35010 Limena (PD)
Tel: +39 049 767 870
Fax: +39 049 767 985
E-Mail: info@HellermannTyton.it
www.HellermannTyton.it

 **HellermannTyton B.V. – Belgium/Netherlands**
Vanadiumweg 11-C
3812 PX Amersfoort
Tel: +31 33 460 06 90
Fax: +31 33 460 06 99
E-Mail (NL): info@HellermannTyton.nl
E-Mail (BE): info@HellermannTyton.be
www.HellermannTyton.nl
www.HellermannTyton.be

 **HellermannTyton AS – Norway**
PO Box 240 Alnabru
0614 Oslo
Tel: +47 23 17 47 00
Fax: +47 22 97 09 70
E-Mail: firmapost@HellermannTyton.no
www.HellermannTyton.no

 **HellermannTyton Sp. z o.o. – Poland**
ul. Berdychów 57A
62-410 Zagórz
E-Mail: info@HellermannTyton.pl
www.HellermannTyton.pl

 **HellermannTyton – Romania**
E-Mail: officeRO@HellermannTyton.at
www.HellermannTyton.at

 **OOO HellermannTyton – Russia**
40/4, Pulkovskoe road
BC Technopolis Pulkovo, office A 8081
196158, St. Petersburg
Tel: +7 812 386 00 09
Fax: +7 812 386 00 08
E-Mail: info@HellermannTyton.ru
www.HellermannTyton.ru

 **HellermannTyton – Slovenia**
Branch Office Ljubljana
Podružnica Ljubljana, Leskoškova 6
1000 Ljubljana
Tel: +386 1 433 70 56
Fax: +386 1 433 63 21
E-Mail: officesl@HellermannTyton.at
www.HellermannTyton.si

 **HellermannTyton España s.l. – Spain/Portugal**
Avda. de la Industria 37.2º D
28108 Alcobendas, Madrid
Tel: +34 91 661 2835
Fax: +34 91 661 2368
E-Mail:

HellermannTyton@HellermannTyton.es
www.HellermannTyton.es

 **HellermannTyton AB – Sweden**
Datavägen 5, PO Box 569
17526 Järfälla
Tel: +46 8 580 890 00
Fax: +46 8 580 890 01
E-Mail: support@HellermannTyton.se
www.HellermannTyton.se

 **HellermannTyton Ltd – UK**
William Prance Road
Plymouth International Medical
and Technology Park
Plymouth, Devon PL6 5WR
Tel: +44 1752 701 261
Fax: +44 1752 790 058
E-Mail: info@HellermannTyton.co.uk
www.HellermannTyton.co.uk

 **HellermannTyton Ltd – UK**
Sharston Green Business Park
1 Robeson Way
Altrincham Road, Wythenshawe
Manchester M22 4TY
Tel: +44 161 947 2200
Fax: +44 161 947 2220
E-Mail: sales@HellermannTyton.co.uk
www.HellermannTyton.co.uk

 **HellermannTyton Ltd – UK**
Main Contact for Customer Service
Wharf Approach
Aldridge, Walsall, West Midlands
WS9 8BX
Tel: +44 1922 458 151
Fax: +44 1922 743 053
E-Mail: info@HellermannTyton.co.uk
www.HellermannTyton.co.uk

 **HellermannTyton Data Ltd – UK**
Cornwell Business Park
43-45 Salthouse Road, Brackmills
Northampton NN4 7EX
Tel: +44 1604 707 420
Fax: +44 1604 705 454
E-Mail: sales@htdata.co.uk
www.htdata.co.uk

Middle East

 **HellermannTyton – UAE**
Email: info@HellermannTyton.ae
www.HellermannTyton.ae

North America

 **HellermannTyton – Canada**
Tel: +1 905 726 1221
Fax: +1 905 726 8538
E-Mail: sales@HellermannTyton.ca
www.HellermannTyton.ca

 **HellermannTyton – Mexico**
Tel: +52 333 133 9880
Fax: +52 333 133 9861
E-Mail: info@HellermannTyton.com.mx
www.HellermannTyton.com

 **HellermannTyton – USA**
Tel: +1 414 355 1130
Fax: +1 414 355 7341
E-Mail: corp@htamericas.com
www.HellermannTyton.com

South America

 **HellermannTyton – Argentina**
Tel: +54 11 4754 5400
Fax: +54 11 4752 0374
E-Mail: ventas@HellermannTyton.com.ar
www.HellermannTyton.com.ar

 **HellermannTyton – Brazil**
Tel: +55 11 4815 9000
Fax: +55 11 4815 9030
E-Mail: vendas@HellermannTyton.com.br
www.HellermannTyton.com.br

Asia-Pacific

 **HellermannTyton – Australia**
Tel: +61 2 9525 2133
Fax: +61 2 9526 2495
E-Mail: cservice@HellermannTyton.com.au
www.HellermannTyton.com.au

 **HellermannTyton – China**
Tel: +86 510 8528 2536
Fax: +86 510 8528 2731
E-Mail: cservice@HellermannTyton.com.cn
www.HellermannTyton.com.cn

 **HellermannTyton – Hong Kong**
Tel: +852 2832 9090
Fax: +852 2832 9381
E-Mail: cservice@HellermannTyton.com.hk
www.HellermannTyton.com.hk

 **HellermannTyton – India**
Tel: +91 120 413 3384
Bangalore: +91 776 001 0104
Chennai: +91 996 264 3939
Faridabad: +91 971 851 7797
Ghaziabad: +91 93 1354 1671
Pune: +91 727 601 2200
E-Mail: cservice@HellermannTyton.co.in
www.HellermannTyton.co.in

 **HellermannTyton – Japan**
Tel: +81 3 5790 3111
Fax: +81 3 5790 3112
E-Mail: mkt@hellermanntyton.co.jp
www.HellermannTyton.co.jp

 **HellermannTyton – Republic of Korea**
Tel: +82 31 388 8012
Fax: +82 31 388 8013
E-Mail: cservice@HellermannTyton.co.kr
www.HellermannTyton.co.kr

 **HellermannTyton – Philippines**
Tel: +63 2 752 6551
Fax: +63 2 752 6553
E-Mail: cservice@HellermannTyton.com.ph
www.HellermannTyton.com.ph

 **HellermannTyton – Singapore**
Tel: +65 6 852 8585
Fax: +65 6 756 6798
E-Mail: cservice@HellermannTyton.sg
www.HellermannTyton.com.sg

 **HellermannTyton – Thailand**
Tel: +662 237 6702 / 266 0624
Fax: +662 266 8664
E-Mail: cservice@HellermannTyton.co.th
www.HellermannTyton.com.sg

Africa

 **HellermannTyton – South Africa**
Tel: +27 11 879 6680
Fax: +27 11 879 6601
E-Mail: sales.jhb@Hellermann.co.za
www.HellermannTyton.co.za

Scan or click!

Order your free
sample pack:



Food & Beverage
sample pack

<http://surl.li/gkvlu>

